

PRODUCT NUMBER
SEE TABLE

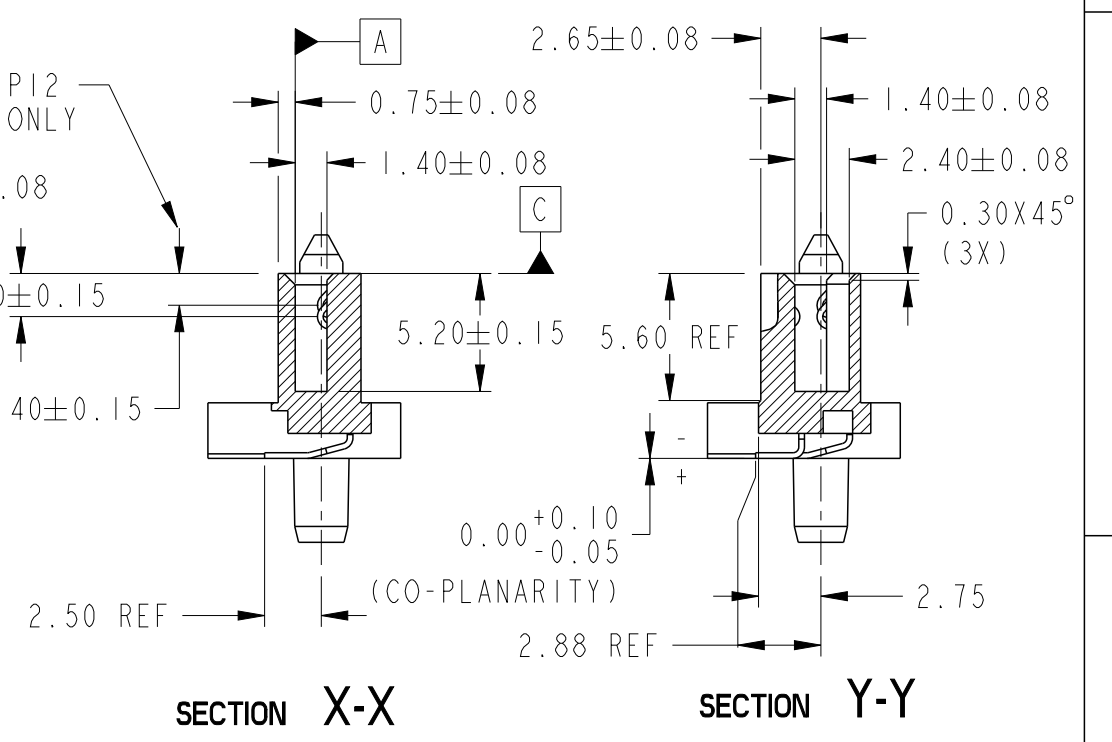
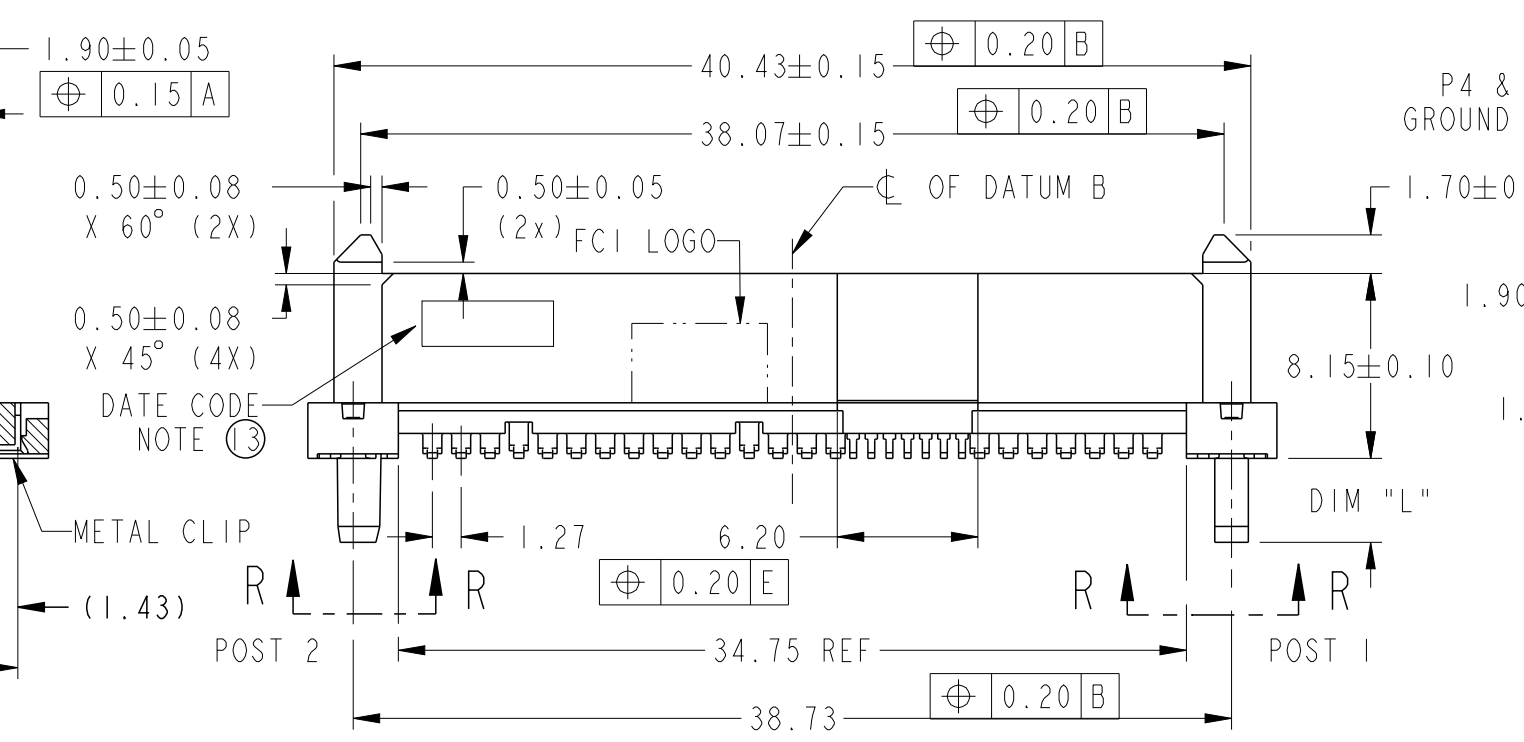
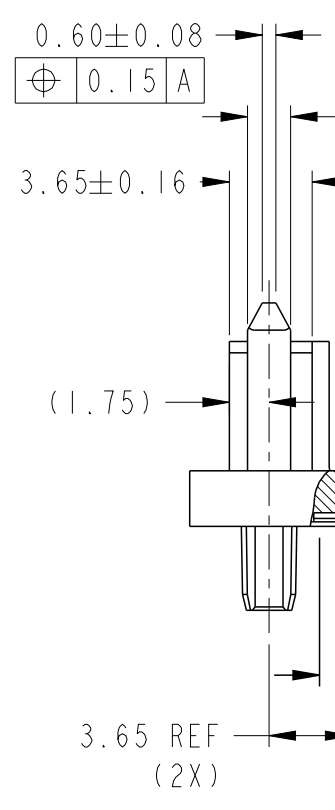
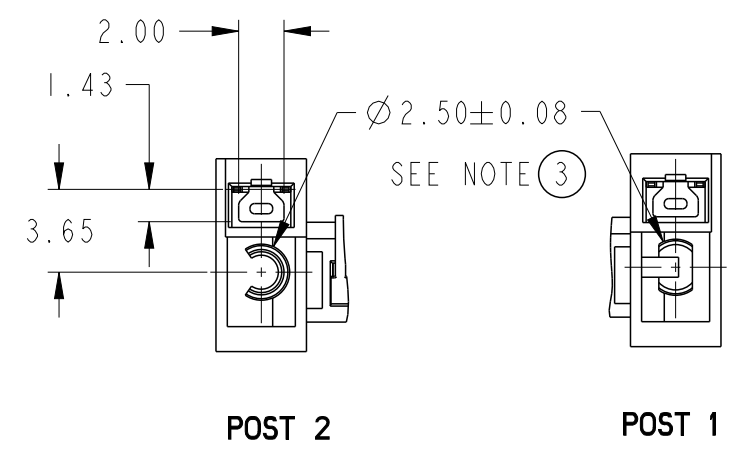
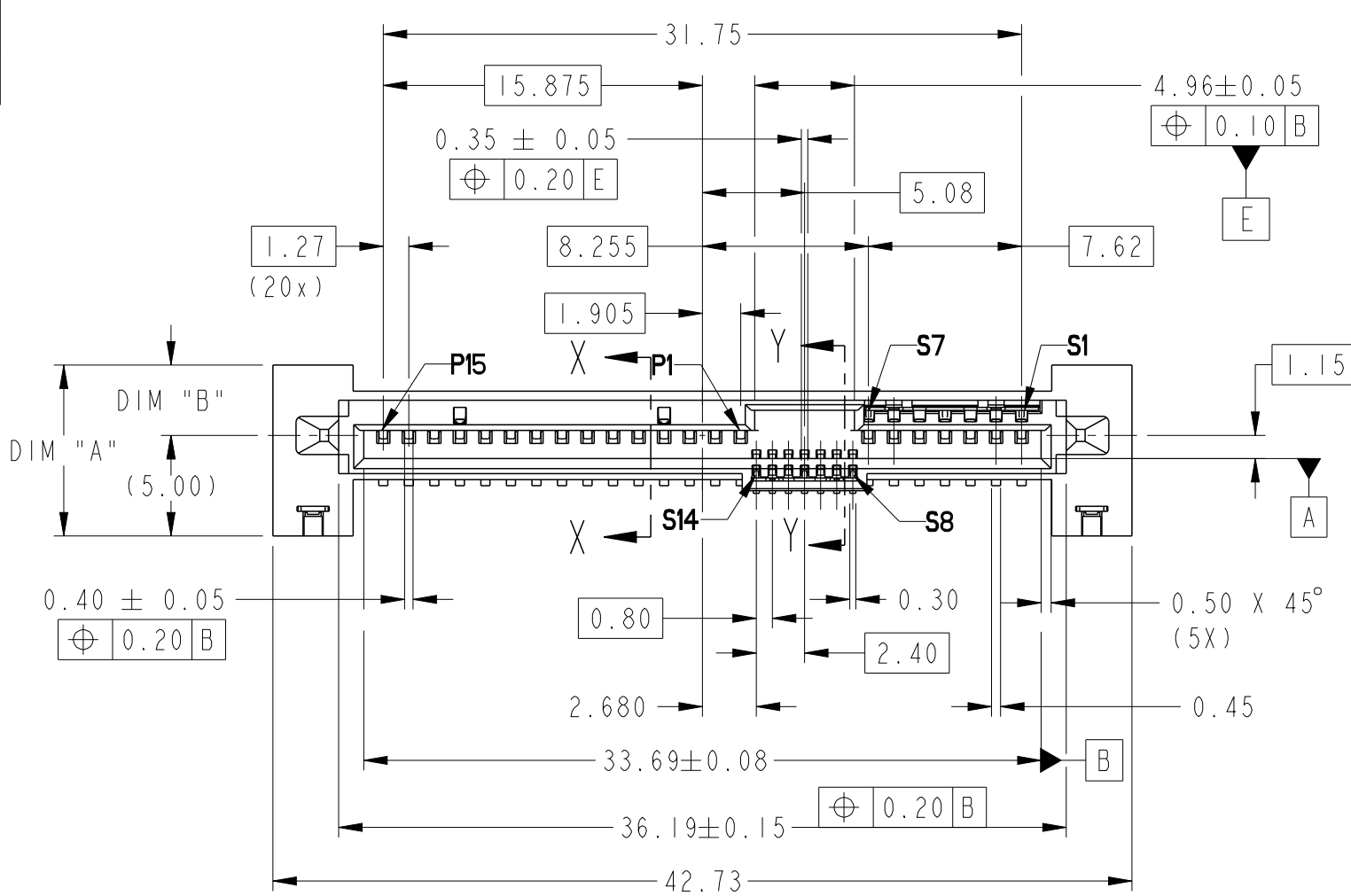

Amphenol FCI
© 2016 AFCI

spec ref	-	dr	Guat-Lian Loo	2013/07/03	projection	MM	size	A3	scale	3:1
tolerance std	ISO 406 ISO 1101	eng	Noorhazlinda	2016/06/14			ecn no	ELX-M-24252-2	rel level	Released
TOLERANCES UNLESS OTHERWISE SPECIFIED		chr	-	app						
surface	linear	0.X	±	Amphenol FCI		part no	10122272		rev	D
		0.XX	±0.20	12G SAS RECEPTACLE		cat. no.	-	Product - Customer Drw	sheet 1 of 3	
		0.XXX	±0.10	WIDE BASE SMT TYPE ASSY						
	angular	0°	±2°							

PRODUCT NO	DIM A	DIM B	DIM L	RECOMMENDED P.C. BOARD THICKNESS	PICK-UP CAP	PACKAGING	REMARK
10122272-001LF	8.50	3.50	3.7	4.57mm (0.018")	NO	TRAY	--
YES							
10122272-001C-TRLF					YES	TAPE & REEL	
10122272-002LF	8.50	3.50	2.0	2.54mm (0.100")	NO	TRAY	--
10122272-002CLF					YES		
10122272-002C-TRLF					YES	TAPE & REEL	
10122272-003LF	7.50	2.50	0.6	1.57mm (0.062")	NO	TRAY	--
10122272-003CLF					YES		
10122272-003C-TRLF					YES	TAPE & REEL	

Amphenol FCI

© 2016 AFCI

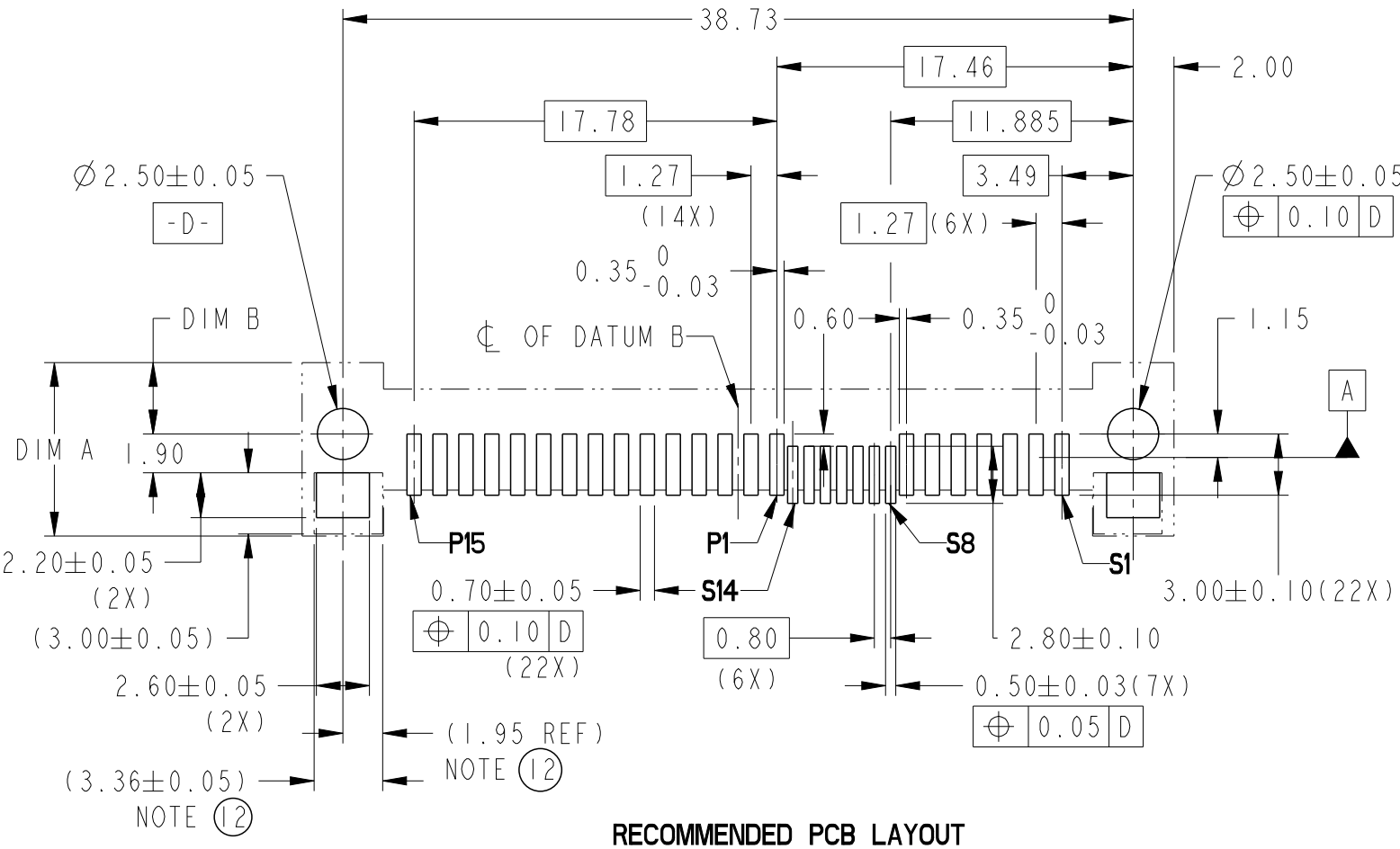
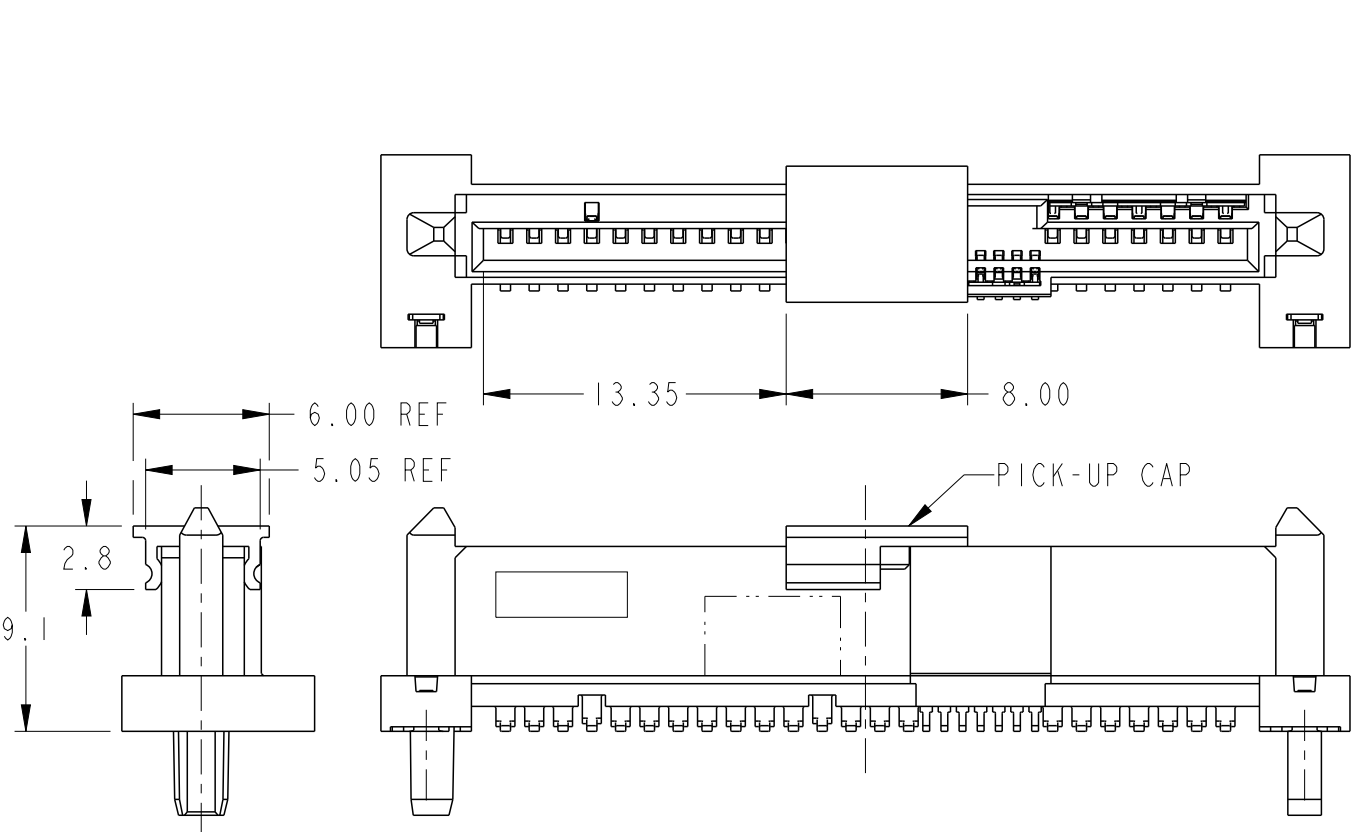

RECOMMENDED PCB LAYOUT
SCALE 3:1

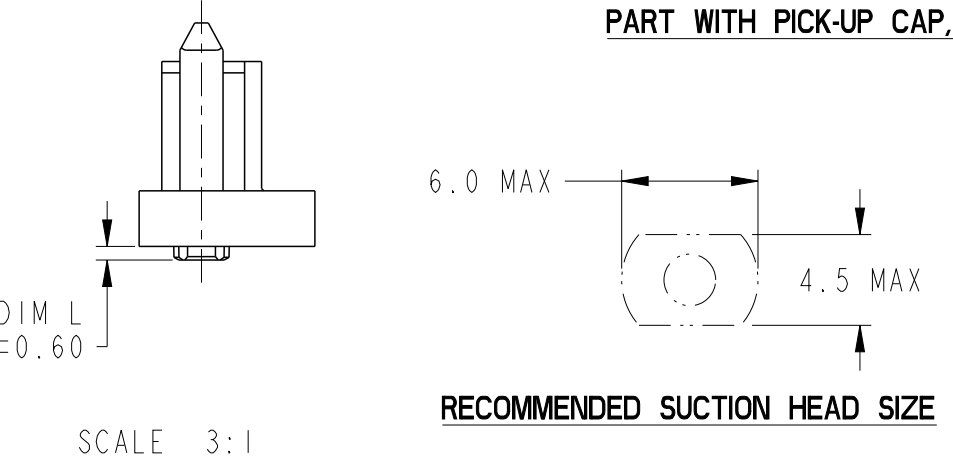

spec ref	-	dr	Guat-Lian Loo	2013/07/03	projection	MM	size	A3	scale	3:1
tolerance std	ISO 406 ISO 1101	eng	Noorhazelinda	2016/06/14			ecn no	ELX-M-24252-2		
TOLERANCES UNLESS OTHERWISE SPECIFIED		chr	-	2016/06/16			product family	SAS	rel level	Released
surface	linear	0.X	±		12G SAS RECEPTACLE		dwg no	10122272		
		0.XX	±0.20		WIDE BASE SMT TYPE ASSY		rev	D		
	angular	0°	±2°		cat. no.	-	Product - Customer Drw	sheet 2 of 3		

PRODUCT NUMBER

SEE TABLE

NOTES:

1. MATERIAL:
 - 1) HOUSING: HIGH TEMP TERMOPLASTIC, UL 94V-0
COLOR : BLACK
 - 2) TERMINAL: COPPER ALLOY
 - 3) HOLD DOWN: COPPER ALLOY
2. FINISH:
 - 1) TERMINAL: 30μ" Au PLATING (CONTACT POINT)
OVER 50μ" NICKEL
 - 2) SOLDER TAIL: 50μ" MIN Sn OVER 50μ" MIN NICKEL
 - 3) HOLD DOWN: 50μ" MIN Sn OVER 50μ" MIN NICKEL
3. THE DIM. IS MEASURED AT P.C. BOARD SITTING PLANE
4. PER SEF REV 1.3 EXCEPT 0.8mm PITCH BUMP AREA
5. PART WITH PICK-UP CAP, P/N XXXXXXXX-XXXC_LF
6. THE STD PACKAGING IS IN TRAY
7. THE TAPE & REEL PACKAGING, SUFFIX "-TR" ADDED AFTER
PRODUCT NUMBER (E.G. XXXXXXXX-XXXC-TRLF)
8. THE HOUSING WILL WITHSTAND EXPOSURE TO 260°C PEAK TEMPERATURE
FOR 10 SECONDS IN A CONVECTION, INFRA-RED OR VAPOR PHASE REFLOW
OVEN.
9. THIS PRODUCT MEETS EUROPEAN UNION DIRECTIVES AND OTHER COUNTRY
REGULATIONS AS DESCRIBED IN GS-47-0004.
10. PART NUMBERS ENDING IN "LF" MEANS FOR NOTE 8 LEAD FREE IDENTIFICATION
11. A  SYMBOL WILL BE NEXT TO ANY DIMENSION, VIEW, OR NOTE WHICH HAS
BEEN MODIFIED WITH THE CURRENT DRAWING REVISION.
12. THE GROUND PAD SIZES SHOWN IN () IS THE COMPETITOR DESIGN FOR REF.
13. DATE CODE LOCATION. DATE CODE NO.YYWW (E.G.14225).
14. CORING AT NON FUNCTIONAL AREAS ARE SUBJECT TO CHANGE WITHOUT NOTICES.

Amphenol
FCi

© 2016 AFCI

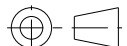
spec ref -		dr	Guat-Lian Loo	2013/07/03	projection	MM	size	A3	scale	3:1
tolerance std		eng	Noorhazlinda	2016/06/14		← →	ecn no		ELX-M-24252-2	
ISO 406 ISO 1101		chr	-	-			rel level		Released	
surface	linear	appr	Koon-Poh Tay	2016/06/16	product family		SAS	rev		
		Amphenol FCi		12G SAS RECEPTACLE		dwg no		10122272		D
				WIDE BASE SMT TYPE ASSY						
ISO 1302	angular			cat. no.	-	Product - Customer Drw		sheet 3 of 3		
		0.X	± -							
		0.XX	±0.20							
		0.XXX	±0.10							
		0°	±2°							