

PART NUMBER	REV	FIRST USED
567912-1	A	854040-3

TERMINAL NAME: PLUG CONTACT, SERIAL BUS					
95-8083-13-2		VISIBLE	CRIMPING DATA		
PAD	LTR		CRIMP HEIGHT		WIRE SIZE
A			.039 ± .002 [0.99 ± 0.05mm]		20
B			.035 ± .002 [0.89 ± 0.05mm]		22
C			.032 ± .002 [0.81 ± 0.05mm]		24
D			NOT		USED
CRIMP	SIZE	TYPE	RANGE		
WIRE	.055 [1.4mm]	F	24-20		
INSUL	.070 [1.78mm]	F	.041-.057		
WIRE STRIP LENGTH	TERM APPL SPEC	FEED	APPL INSTRUCTION	SET UP GAGE	LAYOUT
-	408-8040	.216	SEE CUSTOMER MANUAL	NONE	L1638A

SIM TO HDM 680157

QTY	REV	DESCRIPTION	ITEM NO
			70
			69
			68
			67
			66
			65
			64
			63
			62
			61
			60
			59
			58
			57
			56
			55
			54
			53
			52
			51
			50
			49
			48
			47
			46
			45
			44
			43
			42
			41
			40
			39
			38
			37
			36
			35
			34
			33
			32
			31
			30
			29
			28
			27
			26
			25
			24
			23
			22
			21
			20
			19
			18
			17
			16
			15
			14
			13
			12
			11
			10
			9
			8
			7
			6
			5
			4
			3
			2
			1

QTY	REV	DESCRIPTION	ITEM NO
2	-	C 7-354779-0 PIN, WIRE DISC (.3340)D	129
2	-	C 6-354779-2 PIN, WIRE DISC (.3300)C	128
			127
2	-	C 7-354779-6 PIN, WIRE DISC (.3370)A	126
1	-	A 986950-1 WASHER, FLAT PRECISION	125
			124
1	-	B 690701-2 PLATE, SERIAL NO.	123
			122
1	-	A 4-21028-0 PIN, SLT SPR (#.093x.75) ST 6DE PL	121
			120
2	-	A 21899-2 WASHER, FLAT (#10) S G ADJ BLK	119
			118
2	-	A 21024-5 WASHER, LOCK (#10) ADJ BLOCK	117
			116
			115
2	-	A 21024-2 WASHER, LOCK (#4) FRONT STP GUIDE	114
REF	-	A 21024-4 WASHER, LOCK (#8) FEED FINGER	113
2	-	A 21024-4 WASHER, LOCK (#8) DEP-HOLD	112
REF	-	A 21024-4 WASHER, LOCK (#8) STRIPPER	111
			110
			109
1	-	A 21018-5 NUT, HEX (#6) HOLD DOWN	108
			107
			106
			105
			104
1	-	A 21009-2 SCR, SKT SET (1/4-20x.25 LW) RAM	103
			102
4	-	A 21017-2 SCR, DRIVE (#2x.19) ID PLATE	101
1	-	B 819347-1 PLATE, IDENTIFICATION	100
2	-	A 3-21002-0 SCR, BHC (10-32x.88) DRAG	99
1	-	A 22733-8 SCR, BHC (8-32x.38 LW) ANVIL	98
			97
1	-	A 3-21000-8 SCR, SHC (10-32x.88) MOUNTING	96
1	-	A 2-21002-7 SCR, BHC (10-32x.50) S G ADJ BLK	95
6	-	A 2-21002-2 SCR, BHC (8-32x.50) SHEAR-TERM SUP	94
			93
			92
1	-	A 1-21002-7 SCR, SHC (6-32x.50) CAM	91
2	-	A 2-21000-7 SCR, SHC (8-32x.50) SCR BLK	90
			89
			88
2	-	A 2-21000-8 SCR, SHC (8-32x.56) DEP-HOLD DOWN	87
REF	-	A 2-22603-0 SCR, HEX HD (8-32x.31) FEED FINGER	86
2	-	A 1-21000-3 SCR, SHC (4-40x.25) F ST GUIDE	85
REF	-	A 22733-9 SCR, BHC (8-32x.50 SL) STRIPPER	84
			83
			82
1	-	A 3-22603-1 SCR, HEX (10-32x.38) S G ADJ BL	81
			80
			79
			78
2	-	B 463310-6 BLADE, STRIPPING (#22)	77
			76
			75
1	-	A 690603-1 SPRING, ASSIST	74
1	-	A 23030-1 SCR, SKT CAP (6-32x.25) CP DSC	73
			72
			71

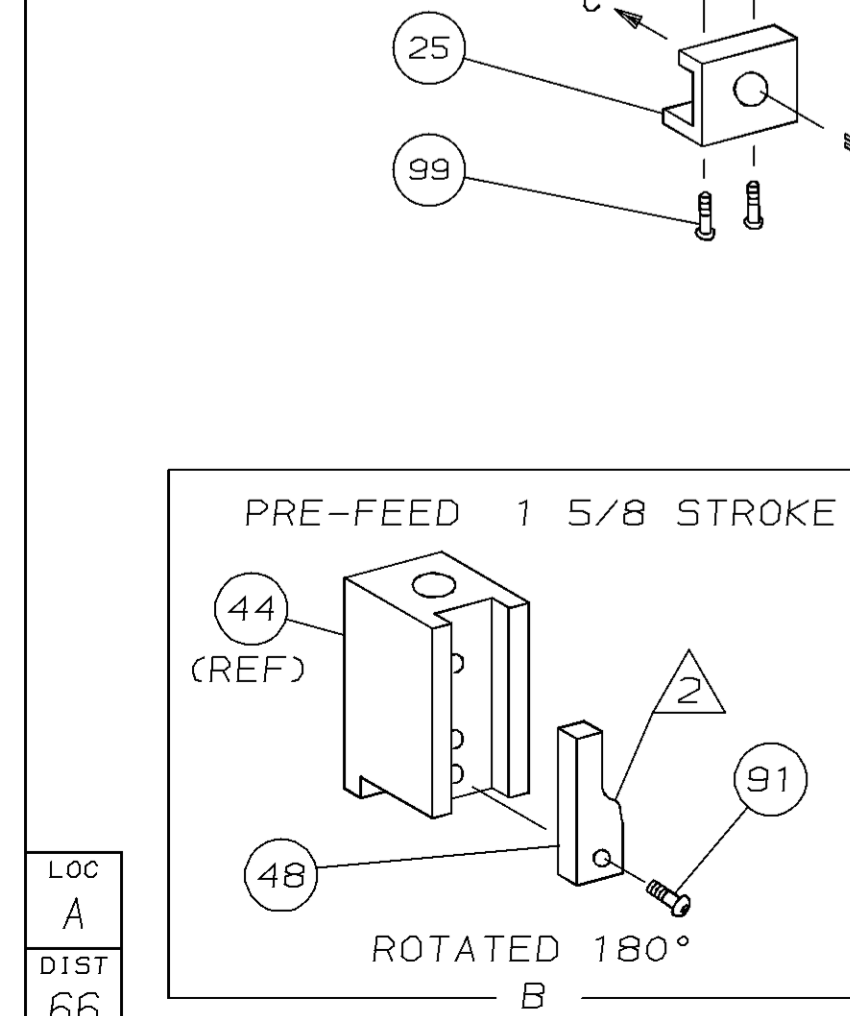

- 1 RECOMMENDED SPARE PARTS.
- 2 GREASE LIGHTLY.
- 3 ITEM NOT SHOWN

QTY REQD PER ASSY	U/M	DWG SIZE	PART NO	DESCRIPTION	ITEM NO
PARTS LIST					

QTY REQD PER ASSY	U/M	DWG SIZE	PART NO	DESCRIPTION	ITEM NO
REVISION OF EACH ASSY NO (WHEN BLANK, USE DWG REVISION)					

DIMENSIONS IN INCHES. DO NOT SCALE PRINT. TOLERANCES UNLESS OTHERWISE SPECIFIED.

DR B. HIGMAN 5/15/95 APP T. BEDDICK 5/15/95
 2 PLC DEC +-
 3 PLC DEC +-
 4 PLC DEC +-
 ANGLES +-
 SURF TEXTURE: ✓
 REMOVE BURRS, BREAK SHARP EDGES R.015 MAX

MATL - HT TR - FIN -

DR B. HIGMAN 5/15/95 APP T. BEDDICK 5/15/95
 CHK 5/15/95 REL 7/26/96
 C. ERISMAN B. MORGAN

NAME STRIPPER CRIMPER APPLICATOR MACHINE REF STRIPPER CRIMPER
 SCALE - DWG NO 567912 SHEET 1 OF 1 REV A

THIS DRAWING IS A CONTROLLED DOCUMENT FOR AMP INCORPORATED. IT IS SUBJECT TO CHANGE AND THE CONTROLLING ENGINEERING ORGANIZATION SHOULD BE CONTACTED FOR THE LATEST REVISION.

THIS INFORMATION IS CONFIDENTIAL AND IS DISCLOSED TO YOU ON CONDITION THAT NO FURTHER DISCLOSURE IS MADE BY YOU TO OTHER THAN AMP PERSONNEL WITHOUT WRITTEN AUTHORIZATION FROM AMP INCORPORATED, HARRISBURG, PA.