

THIS DRAWING IS UNPUBLISHED. RELEASED FOR PUBLICATION
 © COPYRIGHT - By - ALL RIGHTS RESERVED.

LOC		DIST		REVISIONS			
P	LTR	DESCRIPTION		DATE	DWN	APVD	
AF	50	E		REVISED PER ECR-12-013486	08JAN13	KH	KR

SUGGESTED MATING TAB

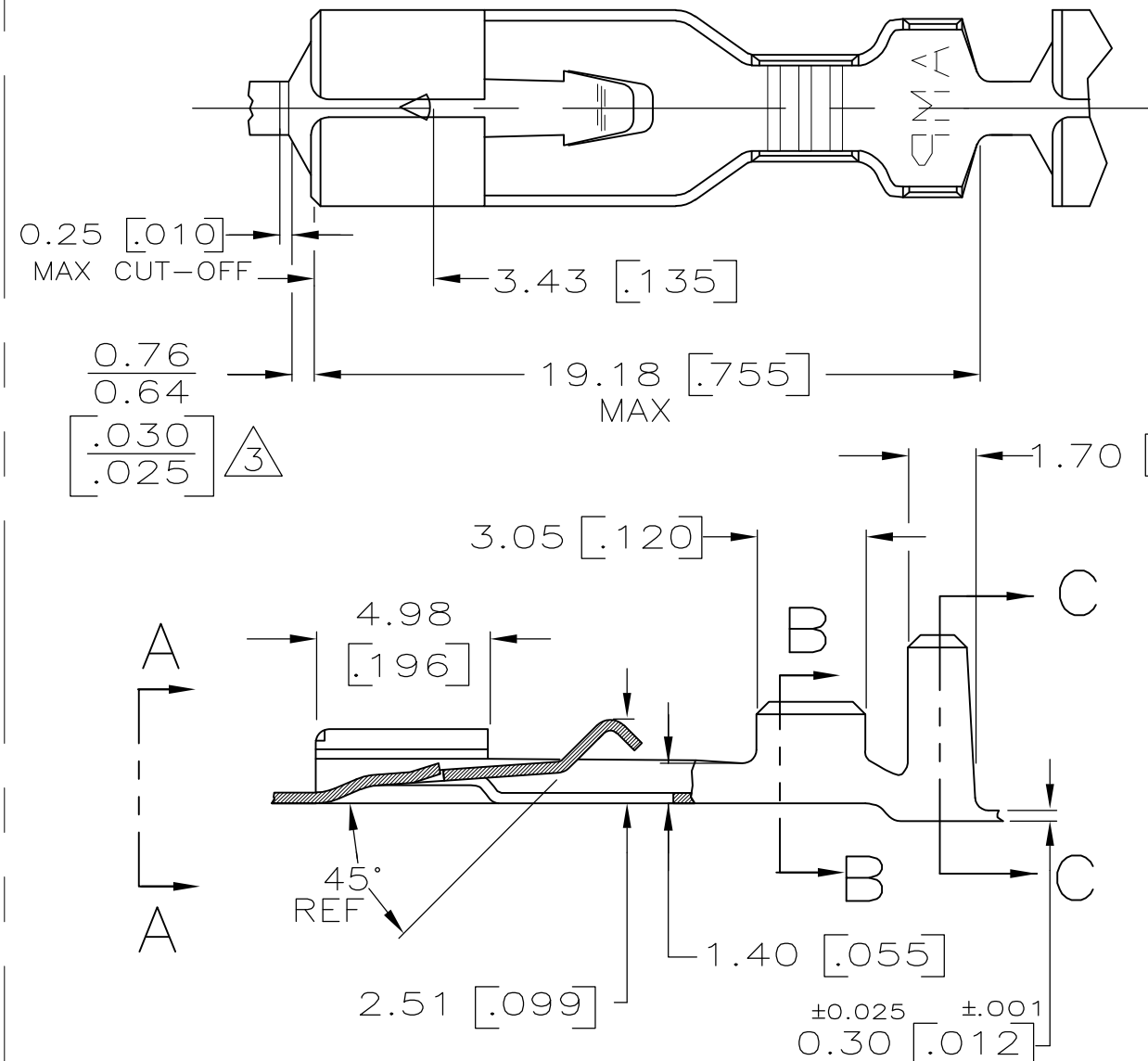
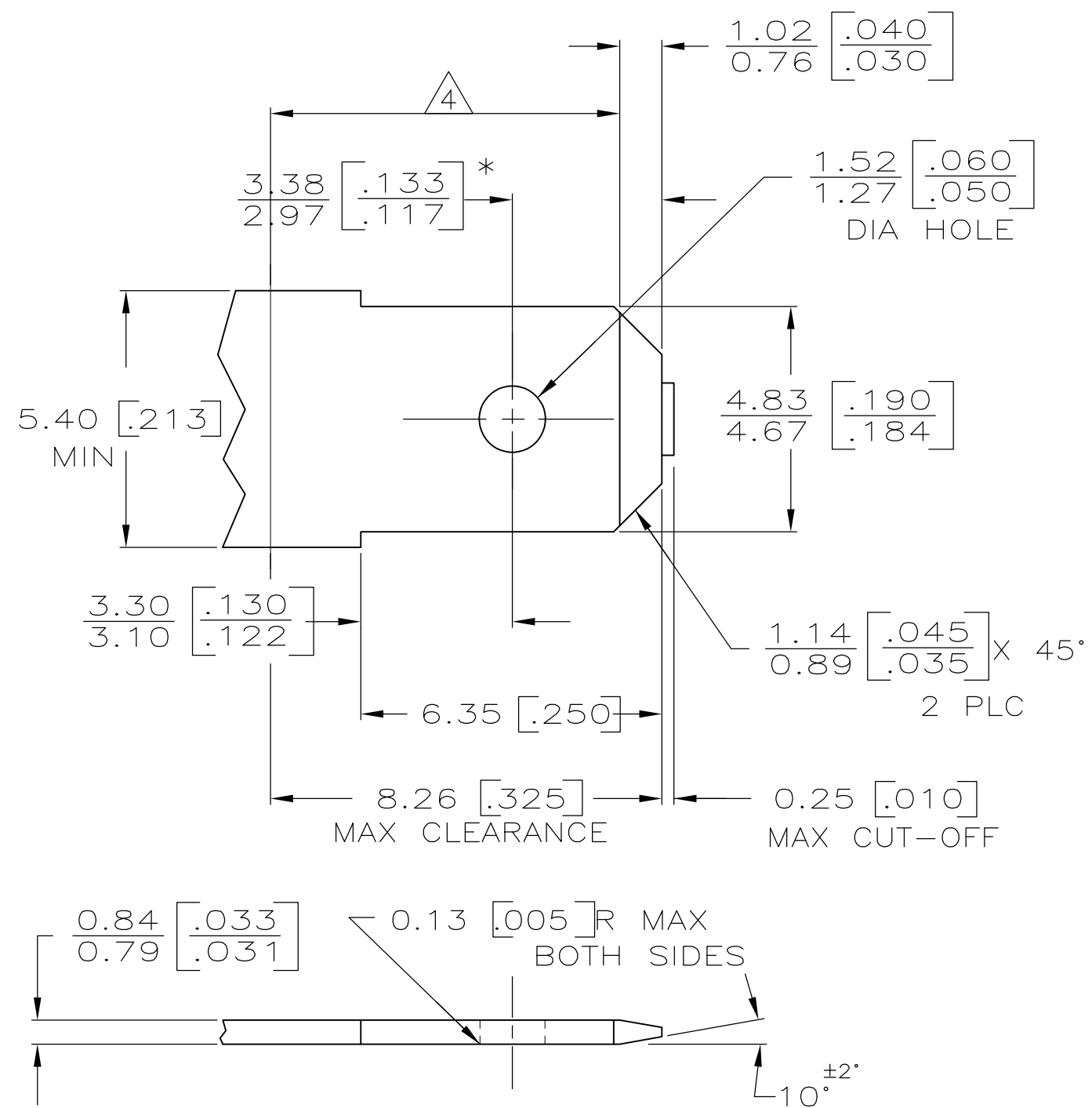

- 1 DIMENSIONS IN BRACKETS ARE IN INCHES.
- 2 CONTINUOUS STRIP ON REELS.
- △ THIS DIMENSIONS MUST BE MAINTAINED FOR PROPER FUNCTION OF THE LATCHING MECHANISM.

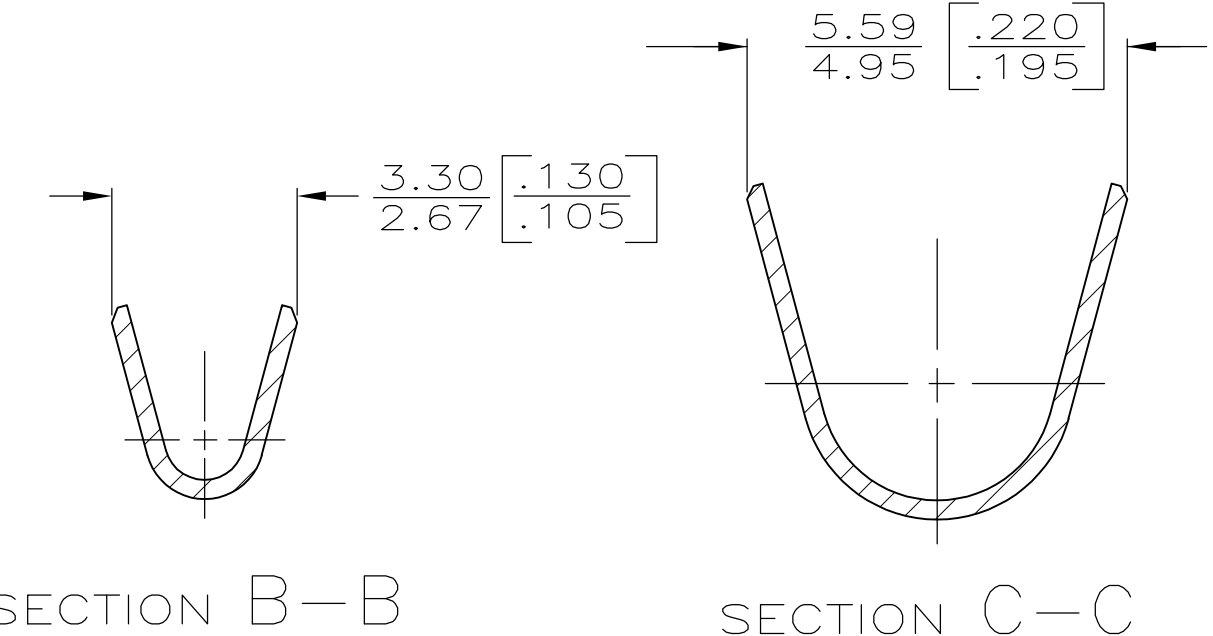
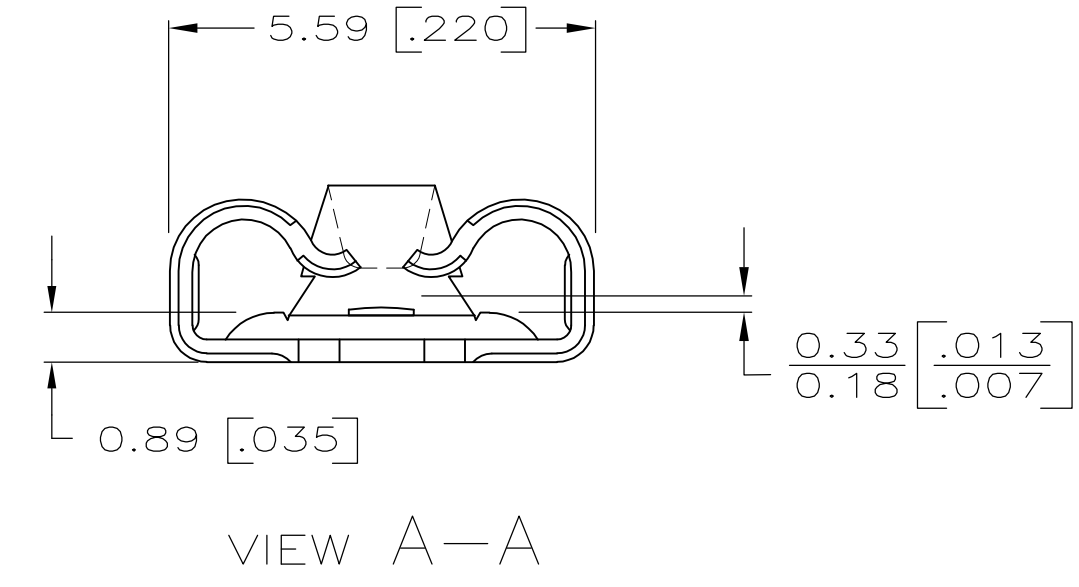

- 1 MATL: #2 HARD BRASS OR NICKEL PLATED STEEL.
- 2 NO BURRS PERMISSIBLE AT HOLE.
- 3 TIN PLATING IS REQUIRED ON BRASS WHEN TERMINAL TEMPERTURE IS OVER 225°F
- △ MUST BE FLAT WITHIN 0.076 [0.003] OVER THIS LENGTH.
- 5 HOLE MUST BE SYMMETRICAL ABOUT TAB \bar{C} WITHIN 0.076 [0.003].
- * TO BE USED ONLY WHEN SHOULDER IS ELIMINATED.

2.29 - 3.30 [0.090 - .130]	0.5 - 1.4mm ² [20-16]	63313-1
INSULATION RANGE		PART NO.
THIS DRAWING IS A CONTROLLED DOCUMENT.		DWN JR RUTH 5/27/87
DIMENSIONS: mm [INCHES]		CHK G YETTER 6/2/87
TOLERANCES UNLESS OTHERWISE SPECIFIED:		APVD R KUZO 6/2/87
0 PLC ± -		NAME
1 PLC ± -		RECEPTACLE, POSITIVE LOCK, .187 SERIES
2 PLC ± -		SIZE
3 PLC ± 0.25 .010		CAGE CODE
4 PLC ± -		DRAWING NO
ANGLES ± -		RESTRICTED TO
FINISH		SCALE
MATERIAL BRASS	FINISH TIN	WEIGHT
CUSTOMER DRAWING		SCALE 1:1
A2 00779 C=63313		SHEET 1 OF 1
REV E		