

LTC5549

2GHz to 14GHz Passive Bidirectional Mixer

DESCRIPTION

Demonstration circuit 2310A is optimized for evaluation of the [LTC®5549](#) passive double-balanced mixer with integrated LO frequency doubler. Its RF port is matched to 50Ω from 2GHz to 13.6GHz with 9dB return loss, and the LO port is matched to 50Ω from 1GHz to 12GHz with 10dB return loss. The IF output is matched to 50Ω from 700MHz to 6GHz with 10dB return loss. The LTC5549 can be used for upconverting and downconverting applications.

The internal LO doubler can be enabled to allow operation with a lower frequency LO input signal such as that from the [LTC6945/LTC6946](#) or [LTC6947/LTC6948](#) family of frequency synthesizers.

Design files for this circuit board are available at <http://www.linear.com/demo/DC2310A>

LT, LT, LTC, LTM, Linear Technology and the Linear logo are registered trademarks of Linear Technology Corporation. All other trademarks are the property of their respective owners.

ABSOLUTE MAXIMUM INPUT RATINGS

Supply Voltage (V_{CC})	4V
Enable Input Voltage (EN)	-0.3V to $V_{CC} + 0.3V$
LO Input Power (1GHz to 12GHz)	+10dBm
LO Input DC Voltage.....	±0.1V
RF Input Power (2GHz to 14GHz)	+20dBm
RF Input DC Voltage.....	±0.1V
IF Input Power (0.5GHz to 6GHz)	+20dBm
IF Input DC Voltage	±0.1V
Operating Temperature Range (T_C)	-40°C to 105°C
Junction Temperature (T_J)	150°C
Storage Temperature Range	-65°C to 150°C

CAUTION: This part is sensitive to electrostatic discharge (ESD). Observe proper ESD precautions when handling the LTC5549.

BOARD LAYOUT

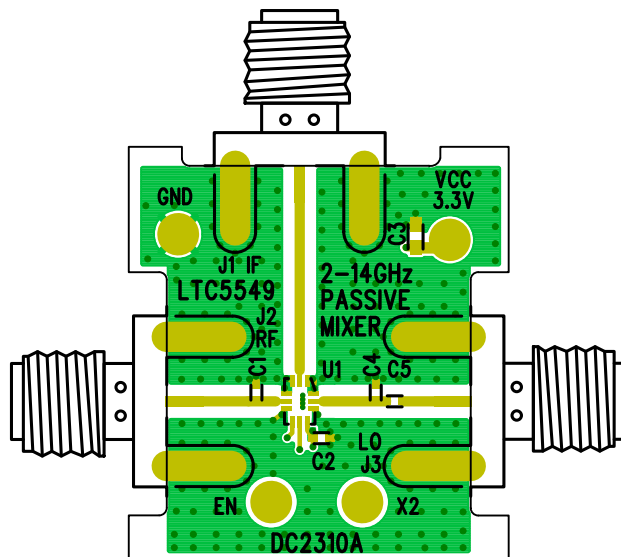

Figure 1. DC2310A

PROPER TEST SETUPS

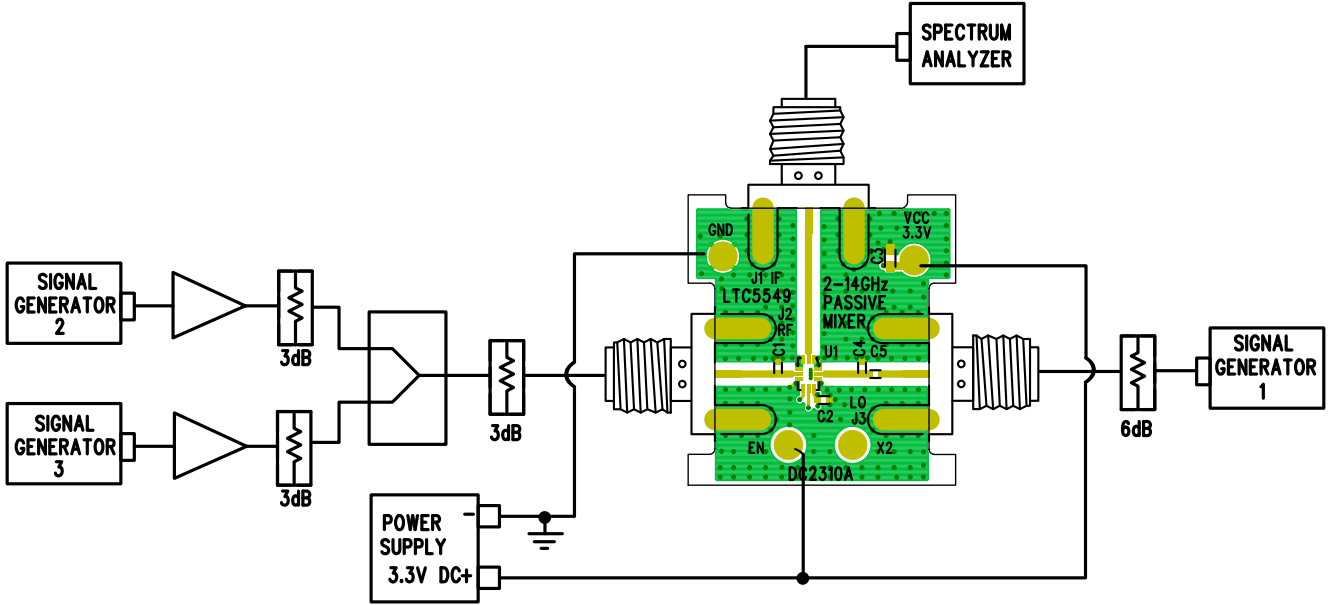

Figure 2. Test Setup for Downconverting Mixer 2-Tone Measurements

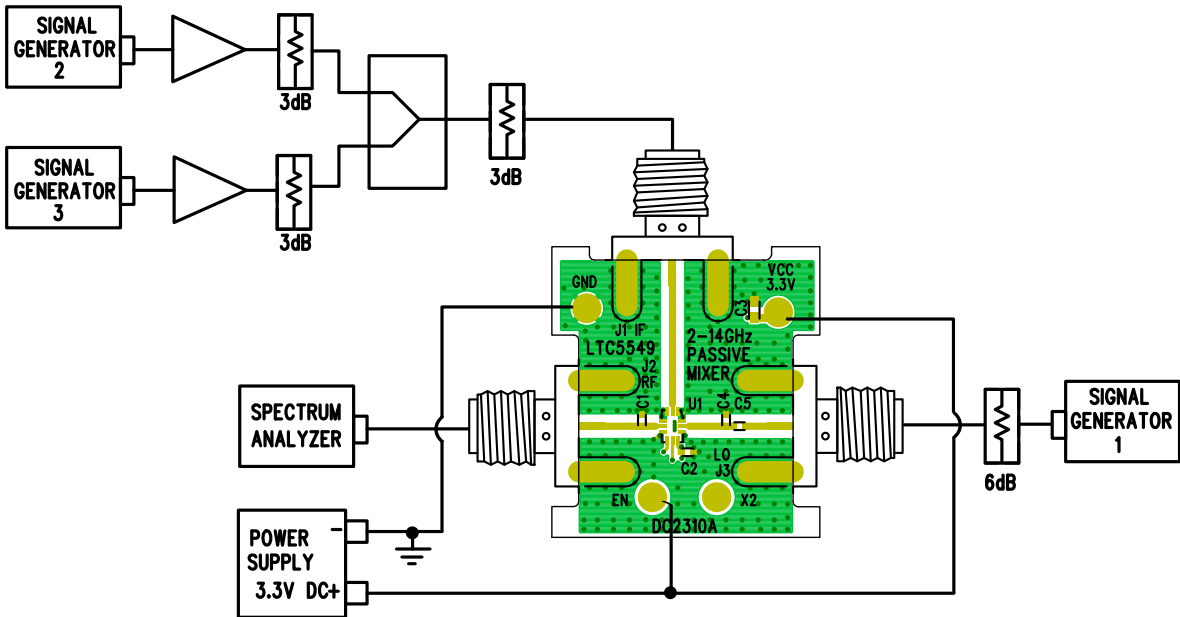

Figure 3. Test Setup for Upconverting Mixer 2-Tone Measurements

NOTES ON TEST EQUIPMENT AND SETUP

- High performance signal generators with low harmonic outputs should be used for 2-tone measurements. Otherwise, low pass filters at the signal generator outputs should be used to suppress harmonics.
- High quality combiners should be used to present a broadband 50Ω termination on all ports as well as provide good port-to-port isolation. Adding attenuator pads further improves source isolation and helps prevent the signal generators from producing intermodulation products.
- Spectrum analyzers can produce significant internal distortion products if they are overdriven. Generally, spectrum analyzers are designed to operate at their best with about -30dBm to -40dBm at their input. The spectrum analyzer's input attenuation setting should be used to avoid saturating the instrument.
- Set the spectrum analyzer's input attenuation depending on the spectrum analyzer used.
- Before performing measurements on the DUT, the system performance should be evaluated to ensure that a clean input signal is obtained and that the spectrum analyzer's internal distortion is minimized.

QUICK START PROCEDURE

1. Connect all test equipment as shown in Figure 2.
2. Set the power supply output voltage to 3.3V, and set the current limit to 200mA.
3. Connect the ground and V_{CC} turrets to the power supply. **BE SURE TO CONNECT THE V_{CC} TURRET *BEFORE* THE EN TURRET TO ENSURE THAT THE PART DOES NOT GET DAMAGED. ALSO, REMOVE POWER FROM EN TURRET *BEFORE* REMOVING POWER FROM THE V_{CC} TURRET.**
4. Connect the EN turret to the power supply.
5. Set the LO signal generator to provide a 3910MHz CW signal at about 0dBm to the demo board's LO port.
6. Set the RF signal generators to provide one 5799MHz CW signal and one 5801MHz CW signal. The signals should be applied to the 2-way combiner. The output of the combiner should be applied to the demo board's RF input port. The two tones should be set to -5dBm each at the mixer's RF input port.
7. Set the spectrum analyzer's center frequency to 1890GHz.
8. Perform various measurements (Conversion Gain, OIP3, LO leakage, etc.)

DEMO MANUAL DC2310A

PARTS LIST

ITEM	QTY	REFERENCE	PART DESCRIPTION	MANUFACTURER/PART NUMBER
1	2	C1, C4	CAP, 0.15pF, 100V, ± 0.01 pF, 0402	AVX, 04021JR15ZBS
2	1	C2, C5	CAP, 22pF, COG, 50V, 5%, 0402	AVX, 04025A220JAT2A
3	2	C3	CAP, 1 μ F, X7R, 10V, 10%, 0603	AVX, 0603ZD105KAT2A
4	4	E1 to E4	TEST POINT, TURRET, 0.061" MTG HOLE	MILL-MAX, 2308-2-00-80-00-00-07-0
5	3	J1 to J3	CONN, SMA 50 Ω EDGE-LAUNCH	EF JOHNS ON, 142-0701-851
6	1	U1	IC LTC5549IUSB, QFN 12 PIN, 3mm x 2mm	LINEAR TECHNOLOGY, LTC5549IUSB#PBF

DEMO BOARD SCHEMATIC

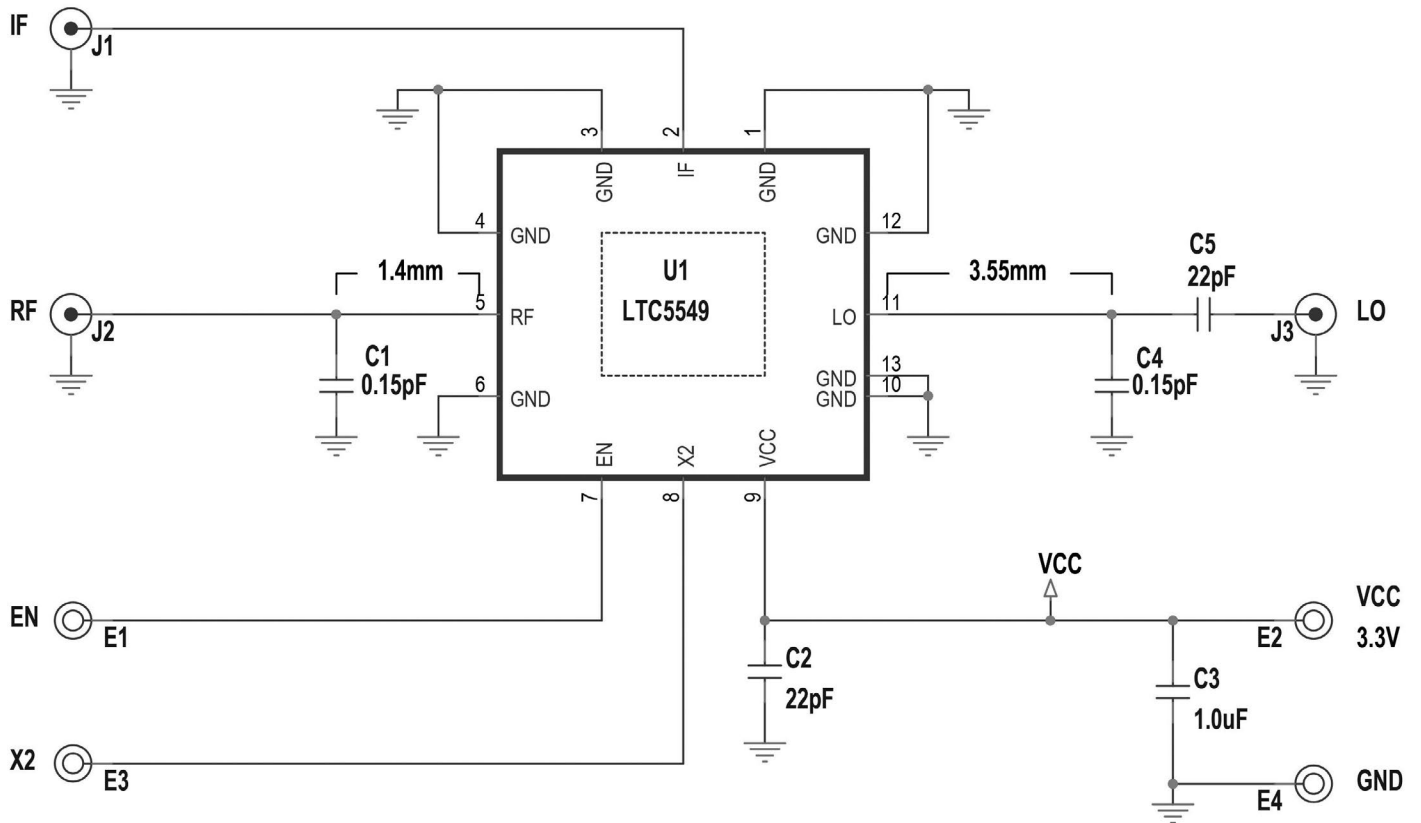

Figure 4. DC2310A Schematic

DEMO MANUAL DC2310A

DEMONSTRATION BOARD IMPORTANT NOTICE

Linear Technology Corporation (LTC) provides the enclosed product(s) under the following **AS IS** conditions:

This demonstration board (DEMO BOARD) kit being sold or provided by Linear Technology is intended for use for **ENGINEERING DEVELOPMENT OR EVALUATION PURPOSES ONLY** and is not provided by LTC for commercial use. As such, the DEMO BOARD herein may not be complete in terms of required design-, marketing-, and/or manufacturing-related protective considerations, including but not limited to product safety measures typically found in finished commercial goods. As a prototype, this product does not fall within the scope of the European Union directive on electromagnetic compatibility and therefore may or may not meet the technical requirements of the directive, or other regulations.

If this evaluation kit does not meet the specifications recited in the DEMO BOARD manual the kit may be returned within 30 days from the date of delivery for a full refund. **THE FOREGOING WARRANTY IS THE EXCLUSIVE WARRANTY MADE BY THE SELLER TO BUYER AND IS IN LIEU OF ALL OTHER WARRANTIES, EXPRESSED, IMPLIED, OR STATUTORY, INCLUDING ANY WARRANTY OF MERCHANTABILITY OR FITNESS FOR ANY PARTICULAR PURPOSE. EXCEPT TO THE EXTENT OF THIS INDEMNITY, NEITHER PARTY SHALL BE LIABLE TO THE OTHER FOR ANY INDIRECT, SPECIAL, INCIDENTAL, OR CONSEQUENTIAL DAMAGES.**

The user assumes all responsibility and liability for proper and safe handling of the goods. Further, the user releases LTC from all claims arising from the handling or use of the goods. Due to the open construction of the product, it is the user's responsibility to take any and all appropriate precautions with regard to electrostatic discharge. Also be aware that the products herein may not be regulatory compliant or agency certified (FCC, UL, CE, etc.).

No License is granted under any patent right or other intellectual property whatsoever. **LTC assumes no liability for applications assistance, customer product design, software performance, or infringement of patents or any other intellectual property rights of any kind.**

LTC currently services a variety of customers for products around the world, and therefore this transaction **is not exclusive**.

Please read the DEMO BOARD manual prior to handling the product. Persons handling this product must have electronics training and observe good laboratory practice standards. **Common sense is encouraged.**

This notice contains important safety information about temperatures and voltages. For further safety concerns, please contact a LTC application engineer.

Mailing Address:

Linear Technology
1630 McCarthy Blvd.
Milpitas, CA 95035

Copyright © 2004, Linear Technology Corporation