

©1960 BY AMP INCORPORATED. ALL RIGHTS RESERVED. AMP PRODUCTS COVERED BY PATENTS AND/OR PATENTS PENDING.

NUMBER 42574

SLEEVE-COLOR SEE TABLE

SLEEVE-MATL: NYLON

.061 ±.008 TAPER PER INCH ON DIA.

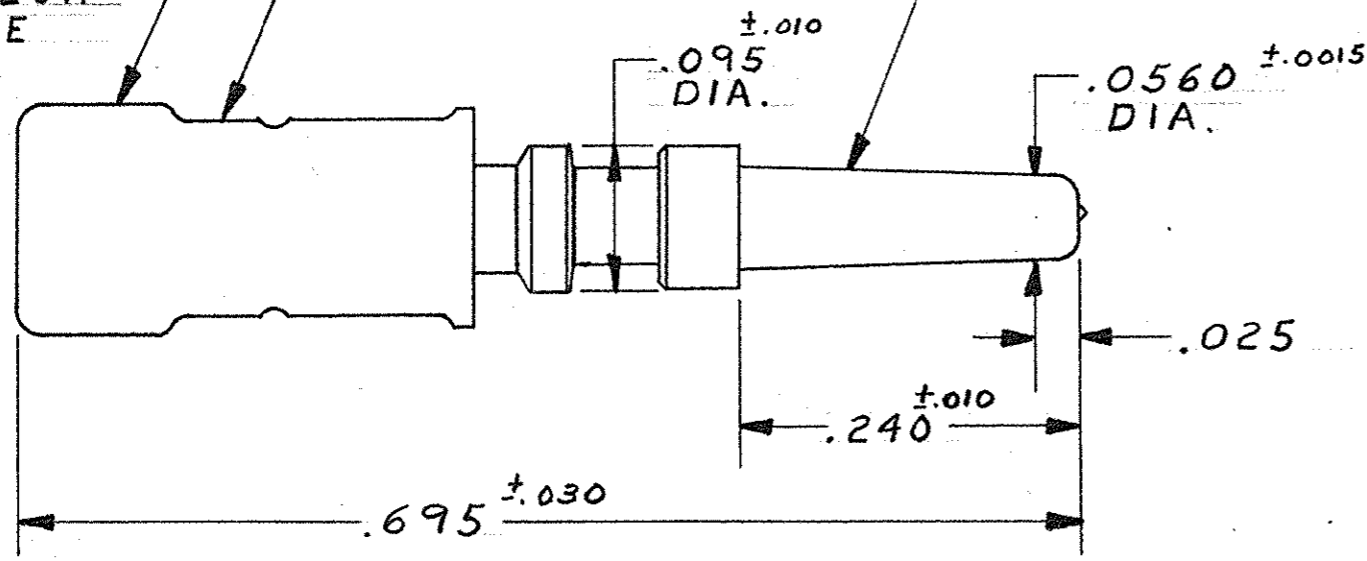

REVISIONS				
ZONE	LTR	DESCRIPTION	DATE	APPROVED
	N-1	REDRAWN AND REVISED 1678	3-15-68	M.S. J.H.
9347	P	LOCS WAS AB, DIST 12 WAS 39	11-7-72	JP
	R	OBSOLETE -6, .0001 BRIGHT TIN WAS .0002, #970	1-31-79	DJA
	S	BRIGHT TIN-LEAD WAS BRIGHT TIN, EA 1818	6-18-81	DS
	T	OBS-7 E-9 ECN 53379	11-22-86	RB
	U	REV PER DF-0357	6/16/88	TS
	V	REV PER OH14-0139-05	1-26-06	PY RB

1. WIRE RANGE: 24-22 INS. RANGE: .040-.080 DIA.

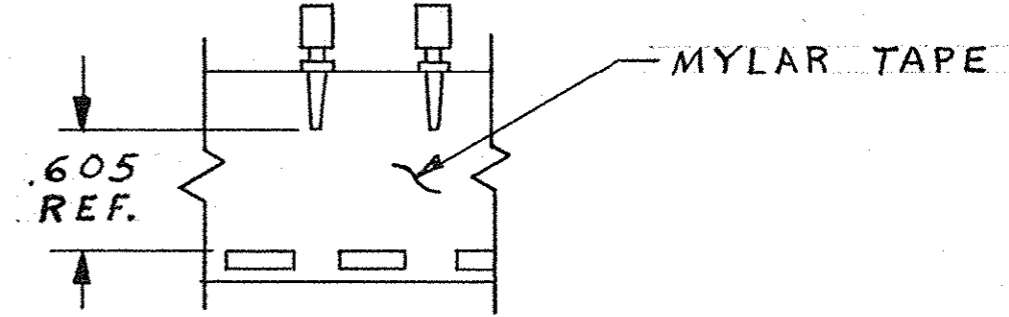

TAPE MOUNTED ASSY. NO'S. 42574-8 THRU 1-42574-1.

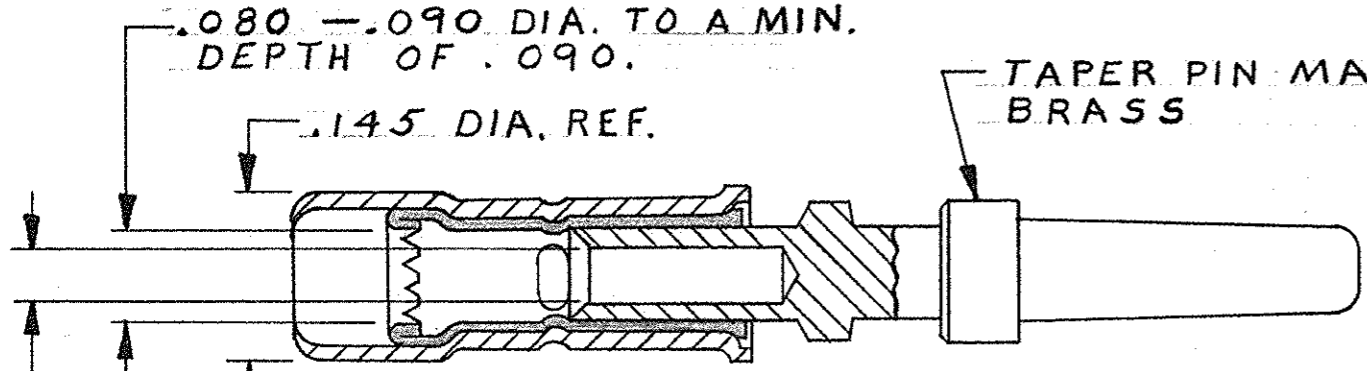

ASSEMBLY BEFORE CRIMPING

	PART NO.	FINISH	SLEEVE-COLOR
	5-42574-1	.0001 MATTE TIN	YELLOW
	1-42574-1	.0002 GOLD OVER .000050 NICKEL	YELLOW
	1-42574-0	.000030 GOLD OVER .000050 NICKEL	
OBSOLETE	42574-9	SILVER-.0002 THICK	
	42574-8	BRIGHT TIN-LEAD .0001 THICK	YELLOW
OBSOLETE	42574-7	.000030 GOLD OVER .000050 NICKEL	BLACK
	42574-6	.000030 GOLD OVER .000050 NICKEL	RED
	42574-5	.0002 GOLD OVER .000050 NICKEL	YELLOW
	42574-4	.0001 GOLD OVER .0001 NICKEL	
	42574-3	.000030 GOLD OVER .000050 NICKEL	
OBSOLETE	42574-2	SILVER-.0002 THICK	
	42574-1	BRIGHT TIN-LEAD .0001 THICK	YELLOW

.033 MIN. DIA.

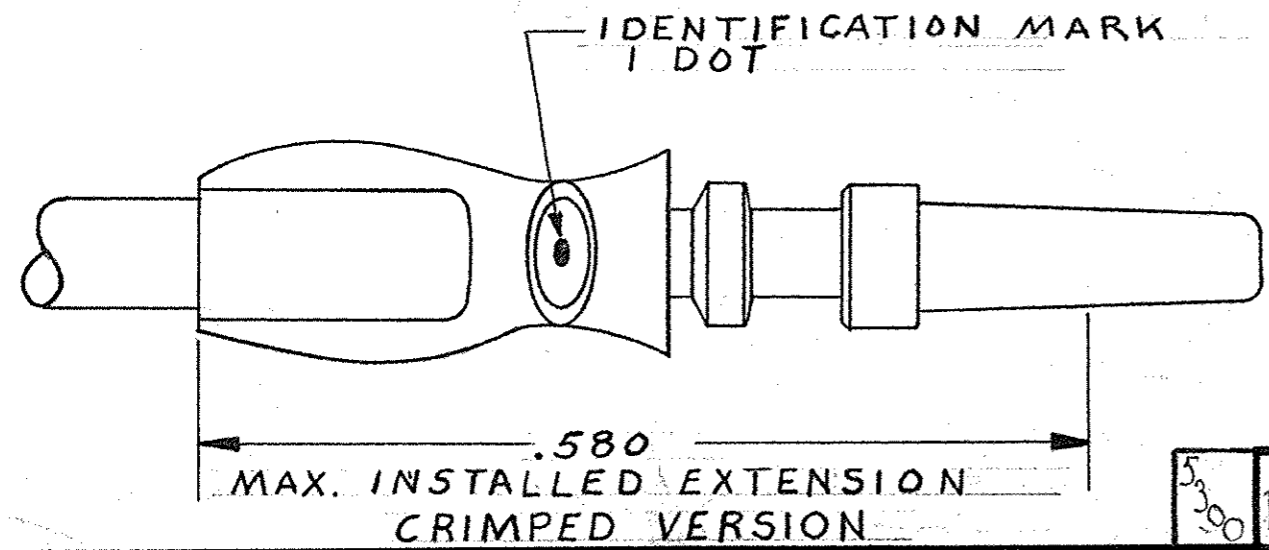

UNLESS OTHERWISE SPECIFIED DIM. ARE IN INCHES. TOLERANCES ON: DECIMALS ±.015 ANGLES ± #

CONTRACT NO. 3-15-68

DR M Smith

CHK J.S. Heide 5/10/68

APPR Hascio H. 5/15/68

DSGN APPD W Feiser 5-15-68

OTHER APPD

MATERIAL SEE CALLOUT

HEAT TREAT #

FINISH SEE TABLE

AMP INFO 53300 DF

AMP AMP INCORPORATED HARRISBURG, PENNSYLVANIA

NAME PIN, TAPER. "53" SERIES, P.I.D.G.

SIZE B CODE IDENT NO. 00779 NUMBER 42574

SCALE 8-1 WT CALC ACTUAL SHEET